

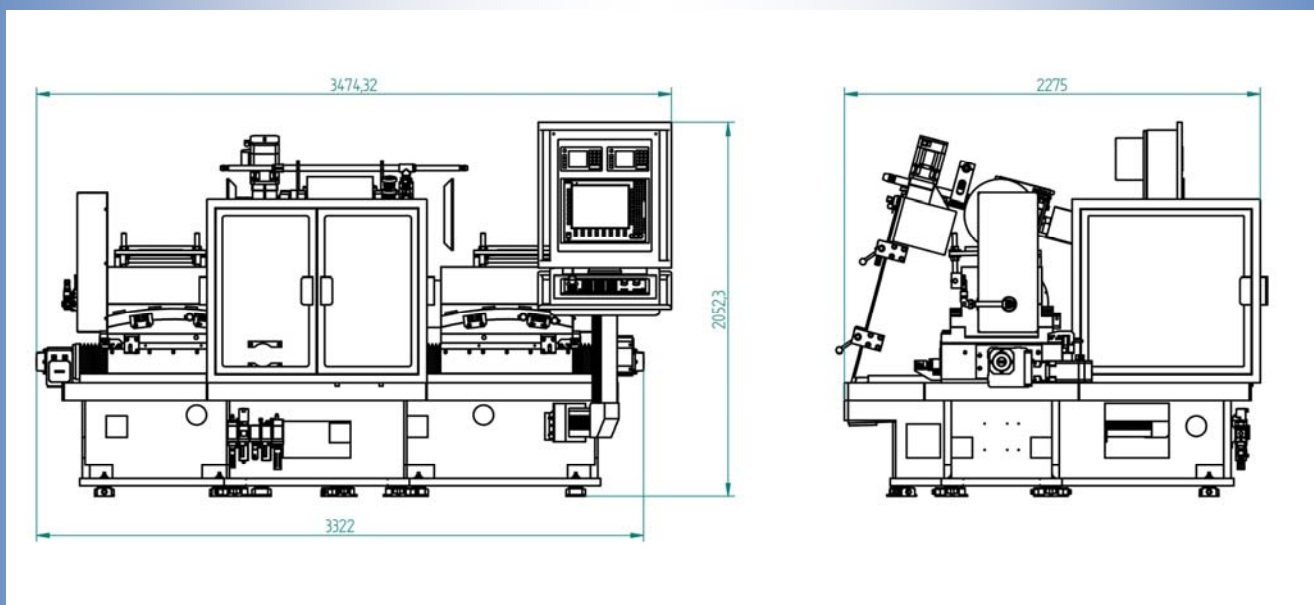

# Double Disc Grinding Machine D660 / 760 / 900 CNC

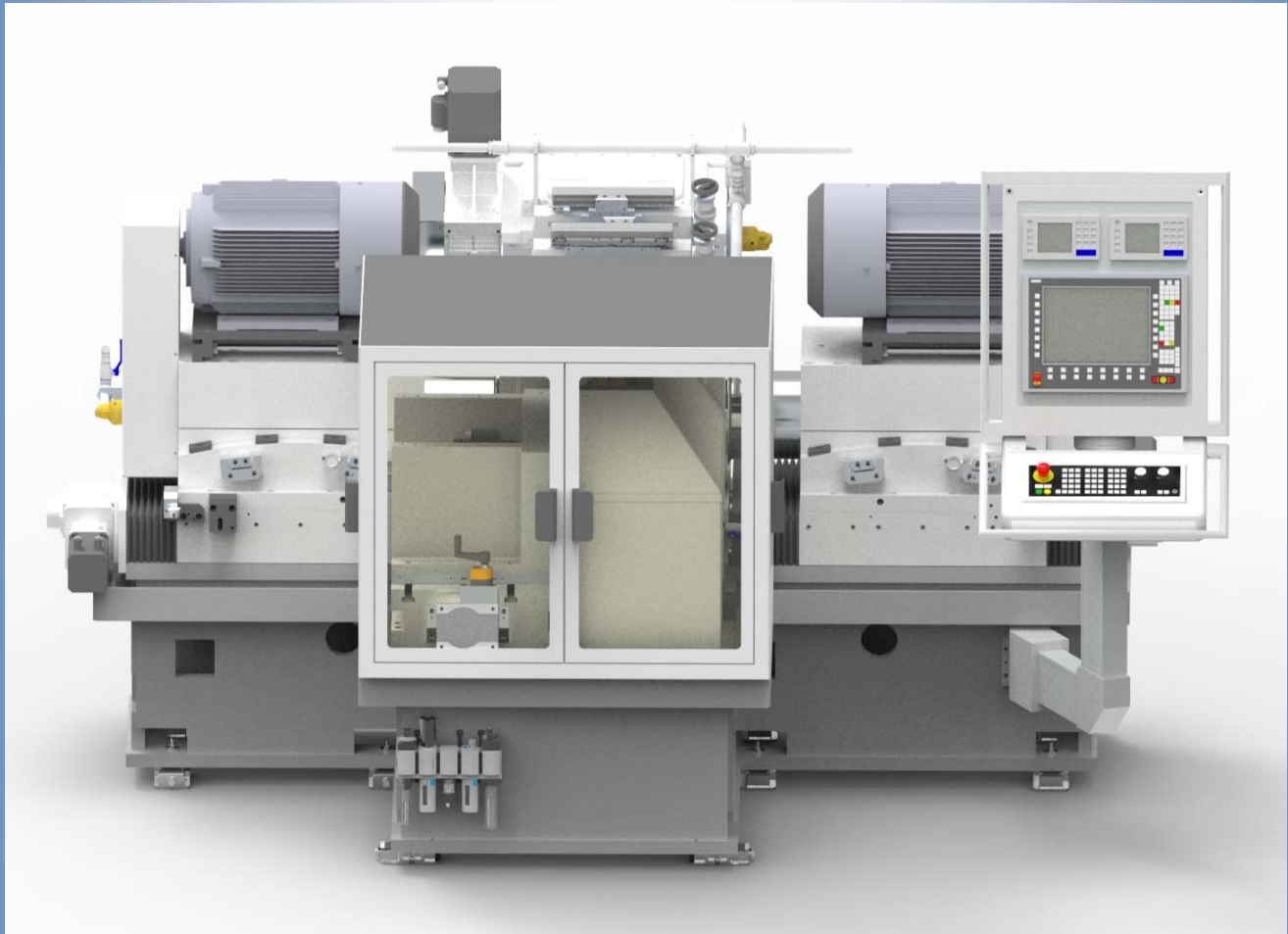



- Advantages of the GIA double face grinding machines:
- Very rigid base frame in T-shape
- Generously dimensioned grinding spindles
- Curved guides for exact adjustment of the tilting
- Adjustment units for grinding spindles with prestressed roller guides and backlash-free ball screws
- Displacement measuring systems for exact positioning of the grinding spindles
- Precise, backlash-free and rigid CNC dressing system
- In-process measuring system, infeed standard 1  $\mu\text{m}$ , on request 0.5  $\mu\text{m}$  (post-process optional)
- Throughfeed and plunge grinding possible
- On request delivery of a fully automated grinding machine - including feed and discharge.

## Technical data

	D660	D760	D900
Dimensions WxHxD in m	3.32 x 2.05 x 2.28	3.32 x 2.05 x 2.28	3.32 x 2.05 x 2.28
Weight in kg	15,000	15,500	17,500
Grinding wheel diameter in mm	660	760	914
Spindle motor power in kW	37 / 45	45	45/55
Max. workpiece dimension D in mm	220	320	420
Controller	840D-SL	840D-SL	840D-SL